

National
Qualifications
2026

X857/75/02

Physics
Section 1 — Questions

THURSDAY, 21 MAY

1:00 PM – 3:30 PM

Instructions for the completion of Section 1 are given on *page 02* of your question and answer booklet X857/75/01.

Record your answers on the answer grid on *page 03* of your question and answer booklet.

Reference may be made to the data sheet on *page 02* of this booklet and to the relationships sheet X857/75/11.

You must leave your answer booklet on your desk; if you do not, you could lose all the marks for this paper.



* X 8 5 7 7 5 0 2 *



DATA SHEET

Speed of light in materials

Material	Speed in m s^{-1}
Air	3.0×10^8
Carbon dioxide	3.0×10^8
Diamond	1.2×10^8
Glass	2.0×10^8
Glycerol	2.1×10^8
Water	2.3×10^8

Speed of sound in materials

Material	Speed in m s^{-1}
Aluminium	5200
Air	340
Bone	4100
Carbon dioxide	270
Glycerol	1900
Muscle	1600
Steel	5200
Tissue	1500
Water	1500

Gravitational field strengths

	Gravitational field strength on the surface in N kg^{-1}
Earth	9.8
Jupiter	23
Mars	3.7
Mercury	3.7
Moon	1.6
Neptune	11
Saturn	9.0
Sun	270
Uranus	8.7
Venus	8.9

Specific heat capacity of materials

Material	Specific heat capacity in $\text{J kg}^{-1} \text{ }^\circ\text{C}^{-1}$
Alcohol	2350
Aluminium	902
Copper	386
Glass	500
Ice	2100
Iron	480
Lead	128
Oil	2130
Water	4180

Specific latent heat of fusion of materials

Material	Specific latent heat of fusion in J kg^{-1}
Alcohol	0.99×10^5
Aluminium	3.95×10^5
Carbon dioxide	1.80×10^5
Copper	2.05×10^5
Iron	2.67×10^5
Lead	0.25×10^5
Water	3.34×10^5

Melting and boiling points of materials

Material	Melting point in $^\circ\text{C}$	Boiling point in $^\circ\text{C}$
Alcohol	-98	65
Aluminium	660	2470
Copper	1077	2567
Lead	328	1737
Iron	1537	2737
Water	-	100

Specific latent heat of vaporisation of materials

Material	Specific latent heat of vaporisation in J kg^{-1}
Alcohol	11.2×10^5
Carbon dioxide	3.77×10^5
Glycerol	8.30×10^5
Turpentine	2.90×10^5
Water	22.6×10^5

Radiation weighting factors

Type of radiation	Radiation weighting factor
alpha	20
beta	1
fast neutrons	10
gamma	1
slow neutrons	3
X-rays	1

SECTION 1 — 25 marks

Attempt ALL questions

1. Which of the following quantities is fully described by its magnitude and direction?

- A Force
- B Distance
- C Time
- D Kinetic energy
- E Mass

2. A student investigates the instantaneous speed of a trolley at a point on a slope using the apparatus shown.

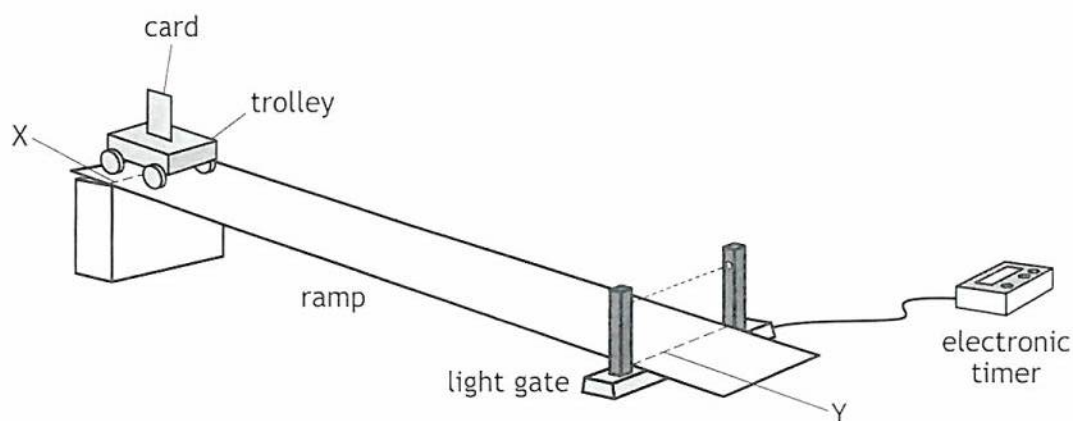

The trolley is released from rest at point X.

The length of the card is 0.052 m.

The distance from point X to point Y is 0.65 m.

The time for the card to pass through the light gate is 0.037 s.

The instantaneous speed of the trolley at point Y is

- A 0.024 m s^{-1}
- B 0.057 m s^{-1}
- C 0.71 m s^{-1}
- D 1.4 m s^{-1}
- E 18 m s^{-1} .

[Turn over

3. A car starts from rest and accelerates at a constant rate.
The car reaches a final speed of 17 m s^{-1} in a time of 1.9 s.
The distance travelled by the car in this time is

- A 4.5 m
- B 8.5 m
- C 8.9 m
- D 16 m
- E 32 m.

4. The mass of a model car is 0.20 kg.
The kinetic energy of the car is 0.90 J.
The speed of the car is

- A 1.5 m s^{-1}
- B 2.3 m s^{-1}
- C 3.0 m s^{-1}
- D 4.5 m s^{-1}
- E 9.0 m s^{-1} .

5. The letters X, Y, and Z represent missing words from the following sentences:

The Sun is an example of aX.....

A natural satellite of a planet is called aY.....

A group of planets that orbit a star is called aZ.....

Which row in the table shows the missing words?

	X	Y	Z
A	solar system	moon	galaxy
B	star	moon	solar system
C	moon	star	solar system
D	star	moon	galaxy
E	moon	star	galaxy

6. During a rocket launch, the thrust of the rocket engine remains constant.

A student makes the following statements about the motion of the rocket during its launch.

- I The acceleration of the rocket increases because the mass of the rocket decreases as fuel is used up.
- II The acceleration of the rocket increases because the unbalanced force acting on the rocket increases.
- III The rocket moves upwards because the exhaust gases exert a downward force on the Earth.

Which of these statements is/are correct?

- A I only
- B II only
- C III only
- D I and II only
- E I, II and III

7. The distance from the Sun to Barnard's Star is 6.0 light-years.

This distance is equivalent to

- A 1.9×10^8 m
- B 1.8×10^9 m
- C 1.6×10^{15} m
- D 9.5×10^{15} m
- E 5.7×10^{16} m.

[Turn over

8. The table gives the distance from the Sun, the approximate mass, and the gravitational field strength of five planets.

Planet	Distance from the Sun ($\times 10^6$ km)	Mass of planet ($\times 10^{24}$ kg)	Gravitational field strength (N kg^{-1})
Venus	110	4.9	8.9
Earth	150	6.0	9.8
Mars	230	0.64	3.7
Jupiter	780	1900	23
Neptune	4500	100	11

A student makes the following statements based on this information:

- I As the distance from the Sun increases, the mass of a planet increases.
- II As the mass of a planet increases, the gravitational field strength increases.
- III There is no apparent relationship between the distance from the Sun and the gravitational field strength of the planet.

Which of these statements is/are correct?

- A I only
- B II only
- C I and III only
- D II and III only
- E I, II and III

9. A conductor carries a current of $8.0 \mu\text{A}$.

The time taken for 0.12 C of charge to pass a point in the conductor is

- A $9.6 \times 10^{-7} \text{ s}$
- B $6.7 \times 10^{-5} \text{ s}$
- C $1.5 \times 10^{-2} \text{ s}$
- D $6.7 \times 10^{-1} \text{ s}$
- E $1.5 \times 10^4 \text{ s}$.

10. The resistance of a lamp increases as the current in the lamp increases.

Which graph shows how the potential difference V across the lamp varies with the current I in the lamp?

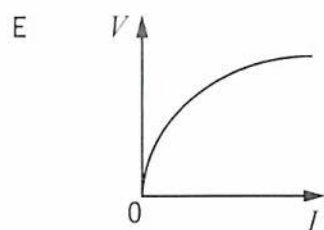
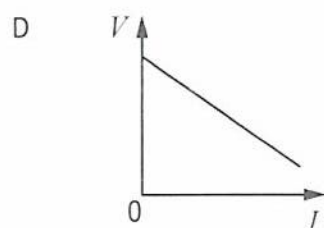
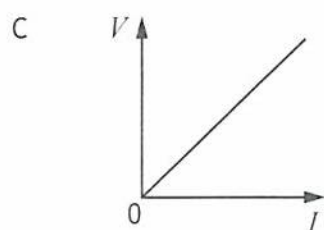
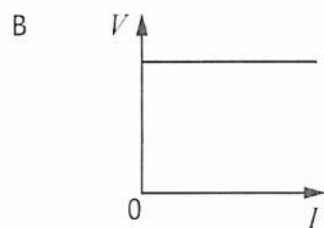
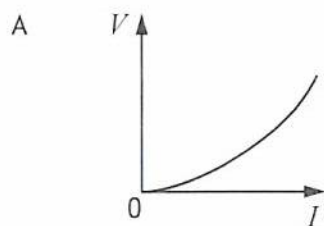

[Turn over

11. A circuit is set up as shown.

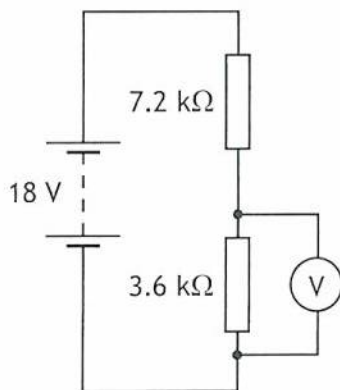

The reading on the voltmeter is

- A 5 V
- B 6 V
- C 9 V
- D 12 V
- E 18 V.

12. A circuit is set up as shown.

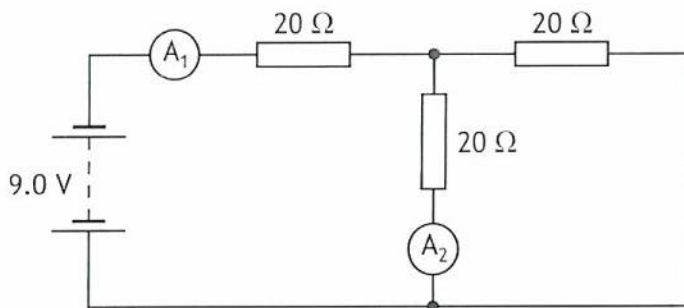

The reading on ammeter A_2 is 0.15 A.

The reading on ammeter A_1 is

- A 0.15 A
- B 0.23 A
- C 0.30 A
- D 0.45 A
- E 0.90 A.

13. A desktop heating plate uses energy from a computer to keep a cup of coffee warm.

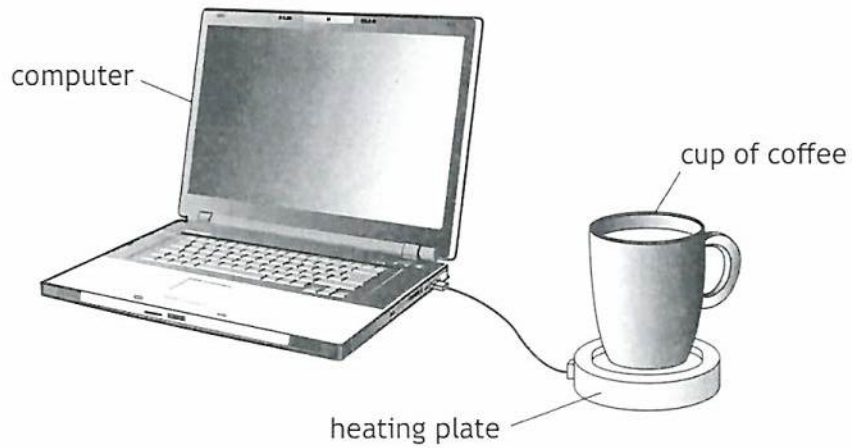

The power of the heater in the heating plate is 2.5 W.

The resistance of the heater in the heating plate is 10Ω .

The heater in the heating plate operates at a voltage of

- A 0.25 V
- B 0.50 V
- C 5.0 V
- D 25 V
- E 230 V.

[Turn over

14. A substance is placed in a container and is cooled. The graph shows how the temperature of the substance varies with time.

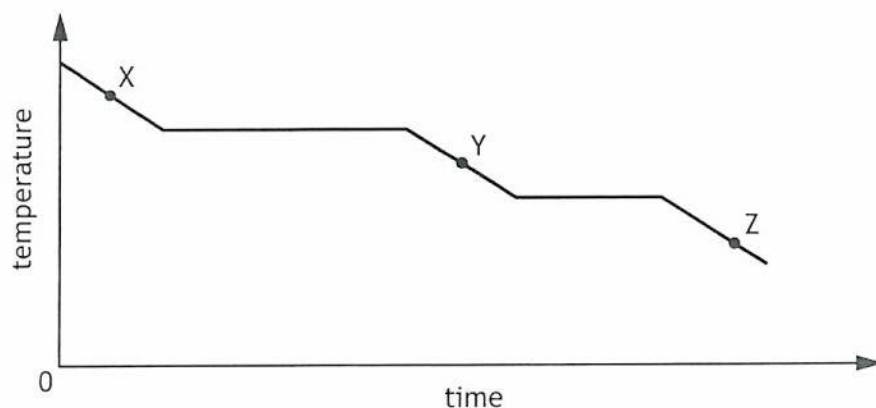

Which row in the table shows the state of the substance at point X, point Y, and point Z?

	Point X	Point Y	Point Z
A	solid	liquid	gas
B	gas	liquid	solid
C	solid	gas	liquid
D	gas	solid	liquid
E	liquid	gas	solid

15. The energy supplied to change ice to water at its melting point is 501 kJ.
The mass of ice converted to water at the same temperature is

- A 2.22×10^{-4} kg
- B 1.50×10^{-3} kg
- C 0.222 kg
- D 0.667 kg
- E 1.50 kg.

16. The volume of a fixed mass of gas in a container is reduced.
The temperature of the gas remains constant.
The pressure of the gas
- A decreases because the gas particles collide with the walls of the container with more force
 - B decreases because the gas particles have less kinetic energy
 - C increases because the gas particles collide more frequently with the walls of the container
 - D decreases because the gas particles collide less frequently with the walls of the container
 - E increases because the gas particles have more kinetic energy.
17. The pressure of a gas inside a sealed rigid container is 1.3×10^5 Pa.
The temperature of the gas is 27°C .
The temperature of the gas is increased to 55°C .
The pressure of the gas is now
- A 6.4×10^4 Pa
 - B 1.2×10^5 Pa
 - C 1.4×10^5 Pa
 - D 2.6×10^5 Pa
 - E 3.6×10^6 Pa.
18. A boat anchored in a harbour rises and falls as waves pass under it.
The boat does not move horizontally.
The boat takes 1.5 seconds to rise from the lowest point of a wave to the highest point.
The wavelength of the waves is 4.5 m.
The speed of the waves is
- A 1.5 m s^{-1}
 - B 3.0 m s^{-1}
 - C 6.0 m s^{-1}
 - D 6.75 m s^{-1}
 - E 13.5 m s^{-1} .

[Turn over

19. The diagram represents a wave.

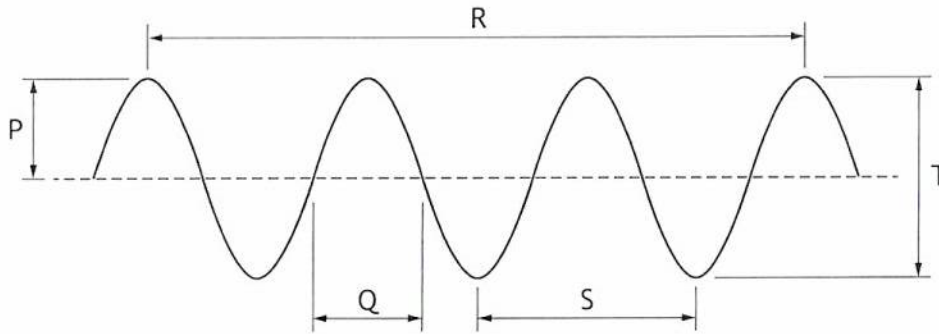

Which row in the table identifies the labels that represent the amplitude and wavelength of the wave?

	Amplitude	Wavelength
A	P	Q
B	P	R
C	P	S
D	T	R
E	T	S

20. A student makes the following statements about the diffraction of waves:

- I Waves with a long wavelength diffract more than waves with a short wavelength.
- II Only radio waves can diffract.
- III During diffraction the speed of the waves changes.

Which of these statements is/are correct?

- A I only
- B II only
- C III only
- D I and II only
- E I, II and III

21. Some telescopes use curved reflectors. The longer the wavelength of the radiation detected, the greater the diameter of the curved reflector needed.

This means the largest curved reflectors are used in telescopes that detect

- A radio waves
- B X-rays
- C visible light
- D gamma radiation
- E infrared radiation.

22. A suitable detector for infrared radiation is

- A an LED
- B a Geiger-Müller tube
- C an aerial
- D fluorescent paint
- E a photodiode.

23. A 3.3 kg sample of a radioactive material is divided into two separate samples, one of mass 1.0 kg and the other of mass 2.3 kg

The 1.0 kg sample of the radioactive material has an activity of 1200 Bq.

In one hour, how many radioactive nuclei decay in the 2.3 kg sample of the radioactive material?

- A 7.7×10^{-1}
- B 2.8×10^3
- C 1.7×10^5
- D 4.3×10^6
- E 9.9×10^6

[Turn over

24. The pilot on an aircraft during flights is exposed to cosmic radiation at an equivalent dose rate of $2.4 \mu\text{Sv h}^{-1}$.

The pilot completes 720 hours of flight time in one year.

The equivalent dose received by the pilot due to cosmic radiation during flights in one year is

- A $3.3 \times 10^{-9} \text{ Sv}$
 B $1.7 \times 10^{-3} \text{ Sv}$
 C $2.1 \times 10^{-2} \text{ Sv}$
 D $1.7 \times 10^3 \text{ Sv}$
 E $3.0 \times 10^8 \text{ Sv}$.
25. In a nuclear reaction a uranium-235 nucleus is split by particle X as shown.

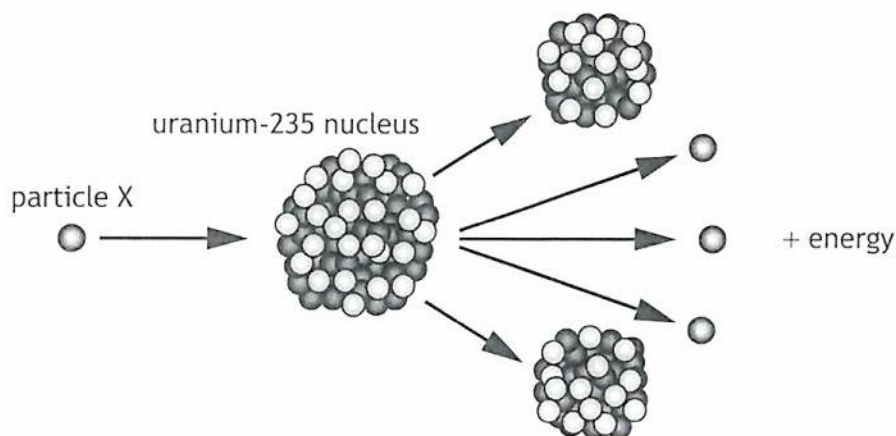

Which row in the table shows the name of particle X and the type of nuclear reaction represented in the diagram?

	Particle X	Type of nuclear reaction
A	proton	fusion
B	neutron	fusion
C	proton	fission
D	neutron	fission
E	electron	fission

[END OF SECTION 1. NOW ATTEMPT THE QUESTIONS IN SECTION 2 OF YOUR QUESTION AND ANSWER BOOKLET]