

National
Qualifications
2026

X857/75/02

Physics
Section 1 — Questions

THURSDAY, 21 MAY

1:00 PM – 3:30 PM

Instructions for the completion of Section 1 are given on *page 02* of your question and answer booklet X857/75/01.

Record your answers on the answer grid on *page 03* of your question and answer booklet.

Reference may be made to the data sheet on *page 02* of this booklet and to the relationships sheet X857/75/11.

You must leave your answer booklet on your desk; if you do not, you could lose all the marks for this paper.



* X 8 5 7 7 5 0 2 *



DATA SHEET

Speed of light in materials

Material	Speed in m s^{-1}
Air	3.0×10^8
Carbon dioxide	3.0×10^8
Diamond	1.2×10^8
Glass	2.0×10^8
Glycerol	2.1×10^8
Water	2.3×10^8

Speed of sound in materials

Material	Speed in m s^{-1}
Aluminium	5200
Air	340
Bone	4100
Carbon dioxide	270
Glycerol	1900
Muscle	1600
Steel	5200
Tissue	1500
Water	1500

Gravitational field strengths

	Gravitational field strength on the surface in N kg^{-1}
Earth	9.8
Jupiter	23
Mars	3.7
Mercury	3.7
Moon	1.6
Neptune	11
Saturn	9.0
Sun	270
Uranus	8.7
Venus	8.9

Specific heat capacity of materials

Material	Specific heat capacity in $\text{J kg}^{-1} \text{ } ^\circ\text{C}^{-1}$
Alcohol	2350
Aluminium	902
Copper	386
Glass	500
Ice	2100
Iron	480
Lead	128
Oil	2130
Water	4180

Specific latent heat of fusion of materials

Material	Specific latent heat of fusion in J kg^{-1}
Alcohol	0.99×10^5
Aluminium	3.95×10^5
Carbon dioxide	1.80×10^5
Copper	2.05×10^5
Iron	2.67×10^5
Lead	0.25×10^5
Water	3.34×10^5

Melting and boiling points of materials

Material	Melting point in $^\circ\text{C}$	Boiling point in $^\circ\text{C}$
Alcohol	-98	65
Aluminium	660	2470
Copper	1077	2567
Lead	328	1737
Iron	1537	2737
Water	-	100

Specific latent heat of vaporisation of materials

Material	Specific latent heat of vaporisation in J kg^{-1}
Alcohol	11.2×10^5
Carbon dioxide	3.77×10^5
Glycerol	8.30×10^5
Turpentine	2.90×10^5
Water	22.6×10^5

Radiation weighting factors

Type of radiation	Radiation weighting factor
alpha	20
beta	1
fast neutrons	10
gamma	1
slow neutrons	3
X-rays	1

SECTION 1 — 25 marks

Attempt ALL questions

1. Which of the following quantities is fully described by its magnitude and direction?

- A Force
- B Distance
- C Time
- D Kinetic energy
- E Mass

2. A student investigates the instantaneous speed of a trolley at a point on a slope using the apparatus shown.

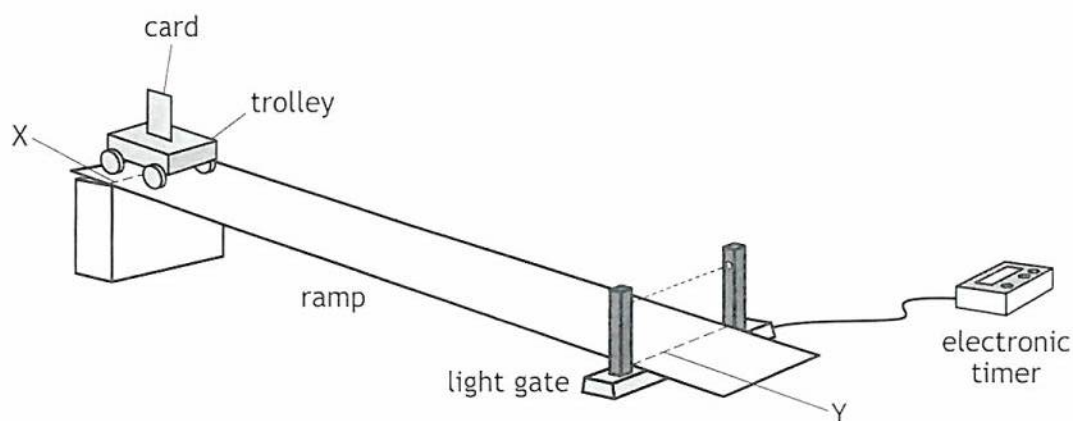

The trolley is released from rest at point X.

The length of the card is 0.052 m.

The distance from point X to point Y is 0.65 m.

The time for the card to pass through the light gate is 0.037 s.

The instantaneous speed of the trolley at point Y is

- A 0.024 m s^{-1}
- B 0.057 m s^{-1}
- C 0.71 m s^{-1}
- D 1.4 m s^{-1}
- E 18 m s^{-1} .

[Turn over

3. A car starts from rest and accelerates at a constant rate.
The car reaches a final speed of 17 m s^{-1} in a time of 1.9 s.
The distance travelled by the car in this time is

- A 4.5 m
- B 8.5 m
- C 8.9 m
- D 16 m
- E 32 m.

4. The mass of a model car is 0.20 kg.
The kinetic energy of the car is 0.90 J.
The speed of the car is

- A 1.5 m s^{-1}
- B 2.3 m s^{-1}
- C 3.0 m s^{-1}
- D 4.5 m s^{-1}
- E 9.0 m s^{-1} .

5. The letters X, Y, and Z represent missing words from the following sentences:

The Sun is an example of aX.....

A natural satellite of a planet is called aY.....

A group of planets that orbit a star is called aZ.....

Which row in the table shows the missing words?

	X	Y	Z
A	solar system	moon	galaxy
B	star	moon	solar system
C	moon	star	solar system
D	star	moon	galaxy
E	moon	star	galaxy

6. During a rocket launch, the thrust of the rocket engine remains constant.

A student makes the following statements about the motion of the rocket during its launch.

- I The acceleration of the rocket increases because the mass of the rocket decreases as fuel is used up.
- II The acceleration of the rocket increases because the unbalanced force acting on the rocket increases.
- III The rocket moves upwards because the exhaust gases exert a downward force on the Earth.

Which of these statements is/are correct?

- A I only
- B II only
- C III only
- D I and II only
- E I, II and III

7. The distance from the Sun to Barnard's Star is 6.0 light-years.

This distance is equivalent to

- A 1.9×10^8 m
- B 1.8×10^9 m
- C 1.6×10^{15} m
- D 9.5×10^{15} m
- E 5.7×10^{16} m.

[Turn over

8. The table gives the distance from the Sun, the approximate mass, and the gravitational field strength of five planets.

Planet	Distance from the Sun ($\times 10^6$ km)	Mass of planet ($\times 10^{24}$ kg)	Gravitational field strength (N kg^{-1})
Venus	110	4.9	8.9
Earth	150	6.0	9.8
Mars	230	0.64	3.7
Jupiter	780	1900	23
Neptune	4500	100	11

A student makes the following statements based on this information:

- I As the distance from the Sun increases, the mass of a planet increases.
- II As the mass of a planet increases, the gravitational field strength increases.
- III There is no apparent relationship between the distance from the Sun and the gravitational field strength of the planet.

Which of these statements is/are correct?

- A I only
- B II only
- C I and III only
- D II and III only
- E I, II and III

9. A conductor carries a current of $8.0 \mu\text{A}$.

The time taken for 0.12 C of charge to pass a point in the conductor is

- A $9.6 \times 10^{-7} \text{ s}$
- B $6.7 \times 10^{-5} \text{ s}$
- C $1.5 \times 10^{-2} \text{ s}$
- D $6.7 \times 10^{-1} \text{ s}$
- E $1.5 \times 10^4 \text{ s}$.

10. The resistance of a lamp increases as the current in the lamp increases.

Which graph shows how the potential difference V across the lamp varies with the current I in the lamp?

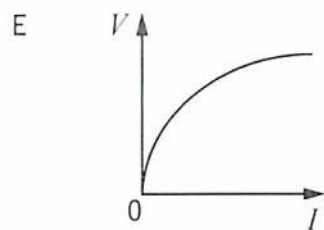
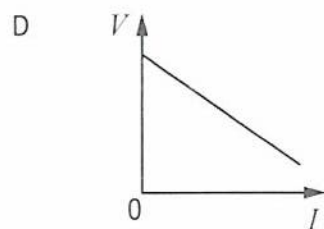
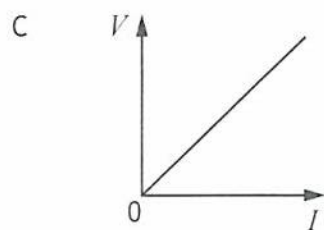
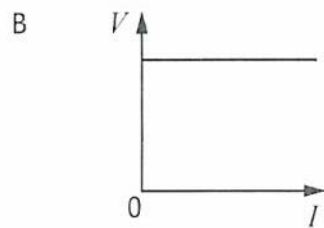
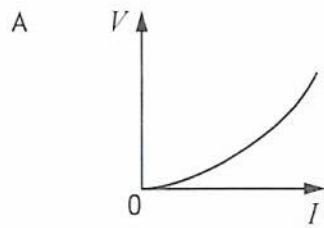

[Turn over

11. A circuit is set up as shown.

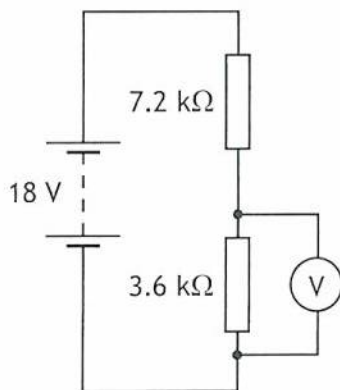

The reading on the voltmeter is

- A 5 V
- B 6 V
- C 9 V
- D 12 V
- E 18 V.

12. A circuit is set up as shown.

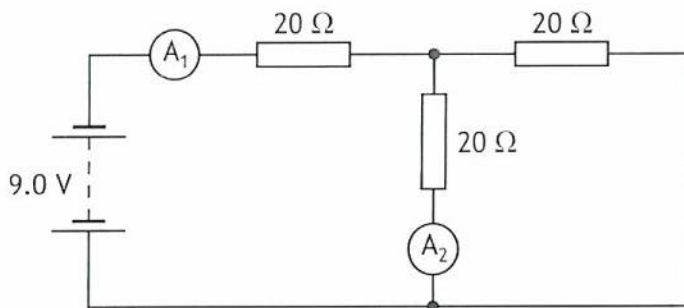

The reading on ammeter A_2 is 0.15 A.

The reading on ammeter A_1 is

- A 0.15 A
- B 0.23 A
- C 0.30 A
- D 0.45 A
- E 0.90 A.

13. A desktop heating plate uses energy from a computer to keep a cup of coffee warm.

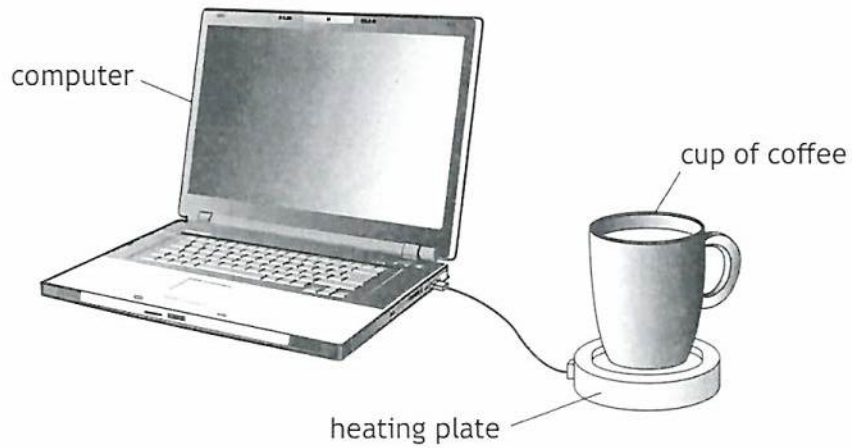

The power of the heater in the heating plate is 2.5 W.

The resistance of the heater in the heating plate is 10Ω .

The heater in the heating plate operates at a voltage of

- A 0.25 V
- B 0.50 V
- C 5.0 V
- D 25 V
- E 230 V.

[Turn over

14. A substance is placed in a container and is cooled. The graph shows how the temperature of the substance varies with time.

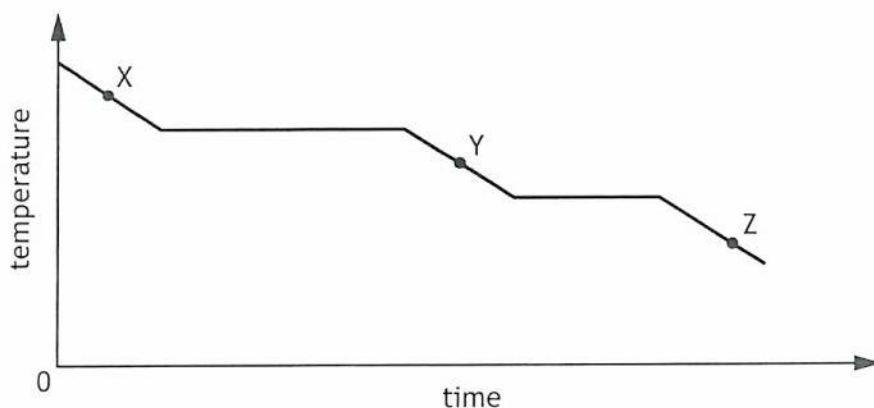

Which row in the table shows the state of the substance at point X, point Y, and point Z?

	Point X	Point Y	Point Z
A	solid	liquid	gas
B	gas	liquid	solid
C	solid	gas	liquid
D	gas	solid	liquid
E	liquid	gas	solid

15. The energy supplied to change ice to water at its melting point is 501 kJ.

The mass of ice converted to water at the same temperature is

- A 2.22×10^{-4} kg
- B 1.50×10^{-3} kg
- C 0.222 kg
- D 0.667 kg
- E 1.50 kg.

16. The volume of a fixed mass of gas in a container is reduced.
The temperature of the gas remains constant.
The pressure of the gas
- A decreases because the gas particles collide with the walls of the container with more force
 - B decreases because the gas particles have less kinetic energy
 - C increases because the gas particles collide more frequently with the walls of the container
 - D decreases because the gas particles collide less frequently with the walls of the container
 - E increases because the gas particles have more kinetic energy.
17. The pressure of a gas inside a sealed rigid container is 1.3×10^5 Pa.
The temperature of the gas is 27°C .
The temperature of the gas is increased to 55°C .
The pressure of the gas is now
- A 6.4×10^4 Pa
 - B 1.2×10^5 Pa
 - C 1.4×10^5 Pa
 - D 2.6×10^5 Pa
 - E 3.6×10^6 Pa.
18. A boat anchored in a harbour rises and falls as waves pass under it.
The boat does not move horizontally.
The boat takes 1.5 seconds to rise from the lowest point of a wave to the highest point.
The wavelength of the waves is 4.5 m.
The speed of the waves is
- A 1.5 m s^{-1}
 - B 3.0 m s^{-1}
 - C 6.0 m s^{-1}
 - D 6.75 m s^{-1}
 - E 13.5 m s^{-1} .

[Turn over

19. The diagram represents a wave.

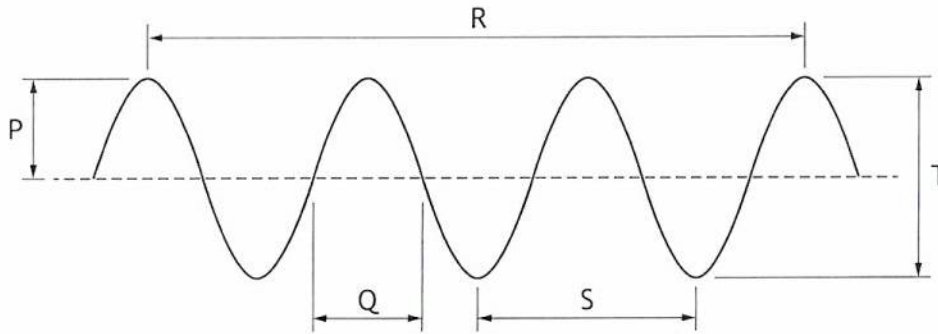

Which row in the table identifies the labels that represent the amplitude and wavelength of the wave?

	Amplitude	Wavelength
A	P	Q
B	P	R
C	P	S
D	T	R
E	T	S

20. A student makes the following statements about the diffraction of waves:

- I Waves with a long wavelength diffract more than waves with a short wavelength.
- II Only radio waves can diffract.
- III During diffraction the speed of the waves changes.

Which of these statements is/are correct?

- A I only
- B II only
- C III only
- D I and II only
- E I, II and III

21. Some telescopes use curved reflectors. The longer the wavelength of the radiation detected, the greater the diameter of the curved reflector needed.

This means the largest curved reflectors are used in telescopes that detect

- A radio waves
- B X-rays
- C visible light
- D gamma radiation
- E infrared radiation.

22. A suitable detector for infrared radiation is

- A an LED
- B a Geiger-Müller tube
- C an aerial
- D fluorescent paint
- E a photodiode.

23. A 3.3 kg sample of a radioactive material is divided into two separate samples, one of mass 1.0 kg and the other of mass 2.3 kg

The 1.0 kg sample of the radioactive material has an activity of 1200 Bq.

In one hour, how many radioactive nuclei decay in the 2.3 kg sample of the radioactive material?

- A 7.7×10^{-1}
- B 2.8×10^3
- C 1.7×10^5
- D 4.3×10^6
- E 9.9×10^6

[Turn over

24. The pilot on an aircraft during flights is exposed to cosmic radiation at an equivalent dose rate of $2.4 \mu\text{Sv h}^{-1}$.

The pilot completes 720 hours of flight time in one year.

The equivalent dose received by the pilot due to cosmic radiation during flights in one year is

- A $3.3 \times 10^{-9} \text{ Sv}$
 B $1.7 \times 10^{-3} \text{ Sv}$
 C $2.1 \times 10^{-2} \text{ Sv}$
 D $1.7 \times 10^3 \text{ Sv}$
 E $3.0 \times 10^8 \text{ Sv}$.
25. In a nuclear reaction a uranium-235 nucleus is split by particle X as shown.

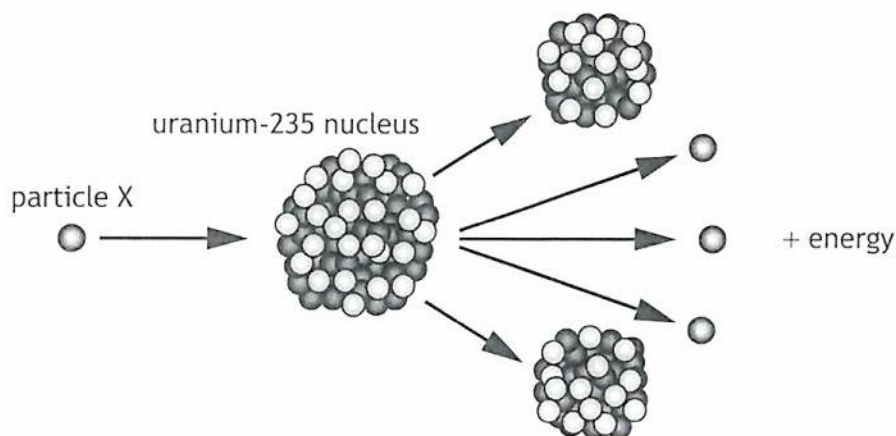

Which row in the table shows the name of particle X and the type of nuclear reaction represented in the diagram?

	Particle X	Type of nuclear reaction
A	proton	fusion
B	neutron	fusion
C	proton	fission
D	neutron	fission
E	electron	fission

[END OF SECTION 1. NOW ATTEMPT THE QUESTIONS IN SECTION 2 OF YOUR QUESTION AND ANSWER BOOKLET]

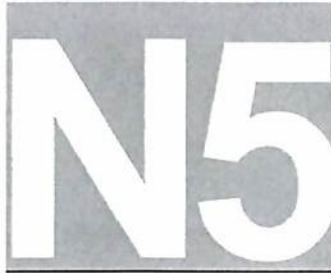

FOR OFFICIAL USE

--	--	--	--	--	--

National
Qualifications
2026

Mark

--

X857/75/01

Physics
Section 1 — Answer grid
and Section 2

THURSDAY, 21 MAY
1:00 PM – 3:30 PM



Fill in these boxes and read what is printed below.

Full name of centre

--

Town

--

Forename(s)

--

Surname

--

Number of seat

--

Date of birth

Day

Month

Year

Scottish candidate number

--	--

--	--

--	--

--	--	--	--	--	--	--	--	--	--

Total marks — 135

SECTION 1 — 25 marks

Attempt ALL questions.

Instructions for completion of Section 1 are given on *page 02*.

SECTION 2 — 110 marks

Attempt ALL questions.

Reference may be made to the data sheet on *page 02* of the question paper X857/75/02 and to the relationships sheet X857/75/11.

Write your answers clearly in the spaces provided in this booklet. Additional space for answers and rough work is provided at the end of this booklet. If you use this space you must clearly identify the question number you are attempting. Any rough work must be written in this booklet. Score through your rough work when you have written your final copy.

Use **blue** or **black** ink.

Do not remove any exam materials. You must leave this booklet on your desk; if you do not, you could lose all the marks for this paper.



SECTION 2 — 110 marks

Attempt ALL questions

1. A student visits an adventure park to experience an aerial ride on a zipline through a forest.



- (a) The student runs from the reception to the starting point of the zipline, following the route shown.

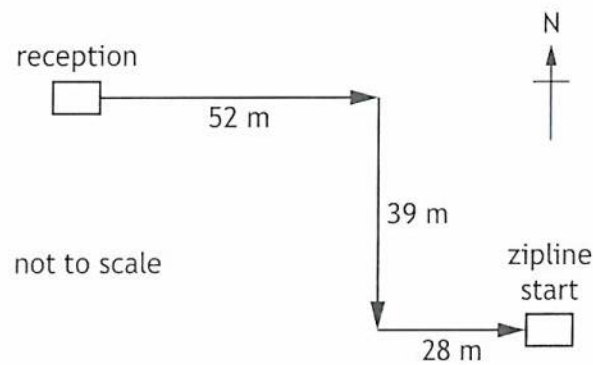

- (i) (A) By scale diagram or otherwise, determine the magnitude of the resultant displacement of the student.

2

Space for working and answer



1. (a) (i) (continued)

(B) By scale diagram or otherwise, determine the direction of the resultant displacement of the student.

2

Space for working and answer

(ii) The student takes 18 s to run from the reception to the starting point of the zipline.

Calculate the average velocity of the student for this journey.

3

Space for working and answer

[Turn over



* X 8 5 7 7 5 0 1 0 7 *

1. (continued)

- (b) The graph shows how the velocity v of the student varies with time t while they are on the zipline.

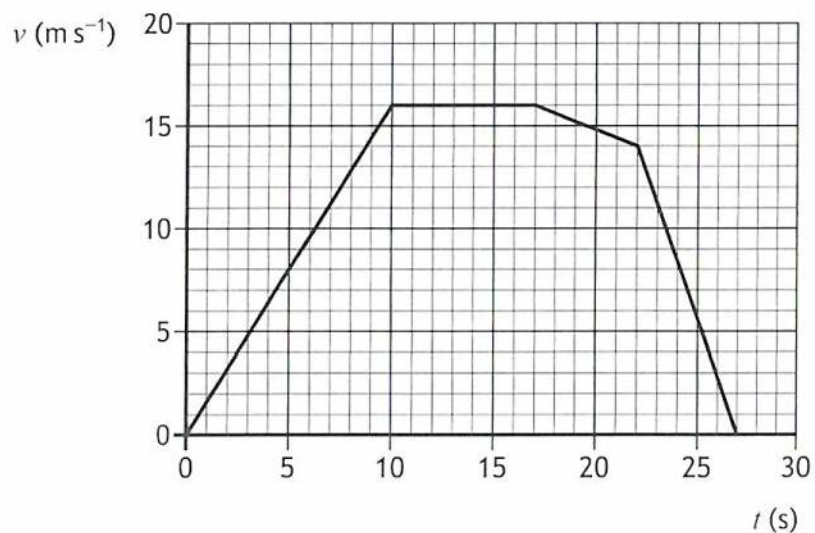

Determine the distance travelled by the student until the point at which they start to slow down.

3

Space for working and answer



2. During a volleyball match, a player hits a volleyball horizontally at a velocity of 13 m s^{-1} over a net.

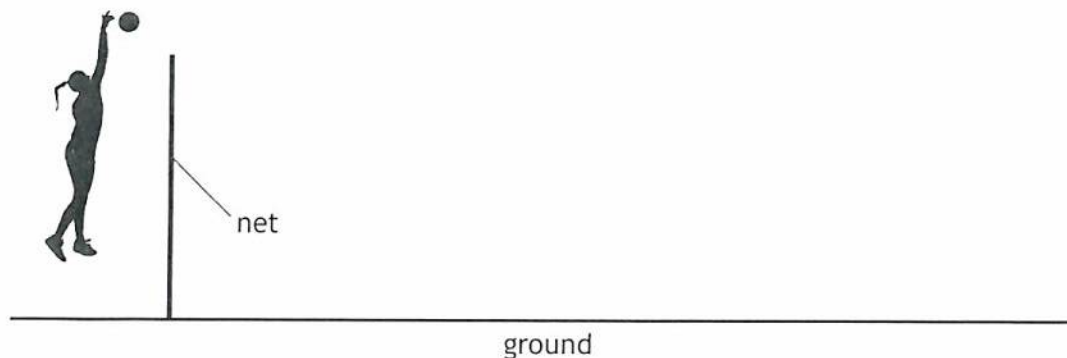

The effects of air resistance are negligible.

- (a) On the diagram above, sketch the path taken by the volleyball from the point it is hit until it reaches the ground. 1
 (An additional diagram, if required, can be found on *page 40*.)
- (b) The horizontal distance travelled by the volleyball from the point it is hit until it reaches the ground is 9.1 m.

- (i) Calculate the time for which the volleyball is in the air, from the point it is hit until it reaches the ground. 3

Space for working and answer

- (ii) Calculate the vertical velocity of the volleyball as it reaches the ground. 3

Space for working and answer



2. (continued)

- (c) Later in the match, the player hits the volleyball horizontally from the same height with a greater velocity.

State whether the time the volleyball is in the air is greater than, the same as, or less than the time calculated in (b) (i).

You must justify your answer.

2

[Turn over



3. Two students make the following statements about satellites.



Student 1: 'Satellites stay in motion because there is no gravity in space.'

Student 2: 'No, satellites stay in motion because they orbit above the Earth's atmosphere, but not all satellites move. Geostationary ones stay in the same place.'

Using your knowledge of physics, comment on the statements made by the students.

3



4. A satellite is transported into space using a rocket.



(a) On the diagram above, show all the forces acting vertically on the rocket just after it leaves the ground.

You must name these forces **and** show their directions.

2

(An additional diagram, if required can be found on *page 40.*)

(b) The total mass of the rocket and satellite at launch is 5.5×10^5 kg.

(i) Show that the weight of the rocket and satellite at launch is 5.4×10^6 N.

2

Space for working and answer



4. (b) (continued)

- (ii) The initial acceleration of the rocket and satellite at launch is 4.1 m s^{-2} .
 Determine the initial upward thrust acting on the rocket.
Space for working and answer

4

[Turn over



4. (continued)

- (c) Once in space, the satellite is released into orbit around Earth.

The graph shows how the distance d travelled by a satellite in one orbit varies with the height h of the satellite above the Earth's surface.

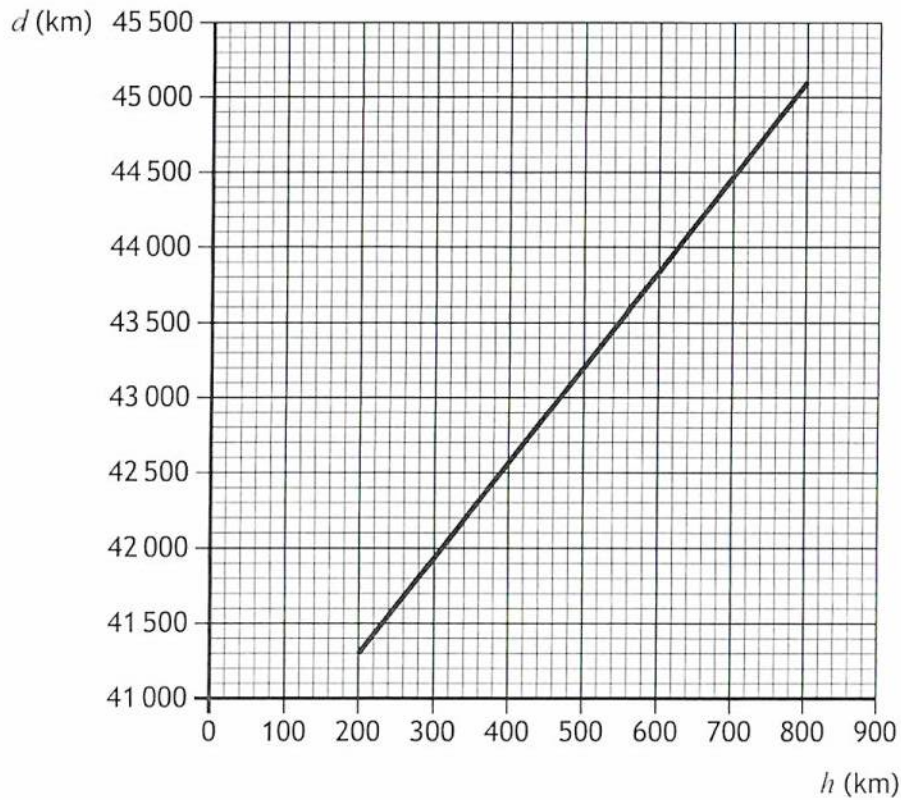

The satellite orbits 550 km above the Earth's surface at a speed of $29\,000 \text{ km h}^{-1}$.

- (i) Determine the time for the satellite to complete one orbit of the Earth. 3

Space for working and answer



4. (c) (continued)

(ii) Determine how many orbits of the Earth the satellite makes in 1 day.

1

Space for working and answer

(d) At the end of its working life the satellite re-enters the Earth's atmosphere.

Explain why the satellite appears as a bright light moving across the sky as it re-enters the atmosphere.

2

[Turn over



* X 8 5 7 7 5 0 1 1 7 *

5. A circuit is set up as shown.

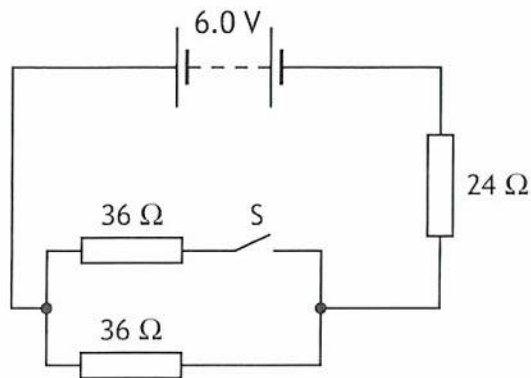

(a) Calculate the voltage across the $24\ \Omega$ resistor when switch S is open.

3

Space for working and answer

(b) Switch S is now closed.

(i) Determine the total resistance of the circuit.

4

Space for working and answer



5. (b) (continued)

(ii) State the effect that closing switch S has on the voltage across the $24\ \Omega$ resistor.

Justify your answer.

3

[Turn over



6. A dishwasher is an appliance used to wash dishes.

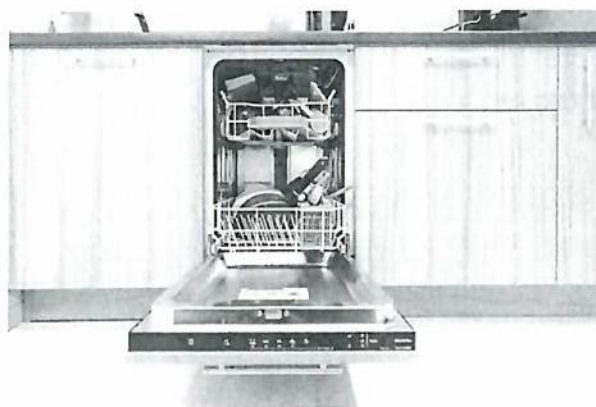

One model of dishwasher has a power rating of 1.5 kW and is connected to a 230 V alternating current (a.c.) supply.

(a) Explain, in terms of electron flow, what is meant by *alternating current (a.c.)*. 1

(b) The plugs on all electrical appliances in the UK are fitted with a fuse rated at either 3 A or 13 A.

(i) Explain how the fuse fitted in the plug prevents the flex of the dishwasher from overheating. 2



6. (b) (continued)

(ii) State the rating of the fuse fitted in the plug of the dishwasher.

Justify your answer by calculation.

Space for working and answer

4

[Turn over



6. (continued)

(c) Water enters the dishwasher at a temperature of 12 °C.

The water is then heated by a heating element.

(i) The dishwasher heats 9.5 kg of water to a temperature of 65 °C during a wash cycle.

Show that the minimum energy required to increase the temperature of the water from 12 °C to 65 °C is 2.1×10^6 J.

2

Space for working and answer

(ii) (A) Calculate the minimum time taken to heat the water from 12 °C to 65 °C.

3

Space for working and answer

(B) Explain why, in practice, it takes longer to heat the water from 12 °C to 65 °C than the time calculated in (c) (ii) (A).

1



6. (continued)

- (d) Part of the circuit used to control the temperature of the water in the dishwasher is shown.

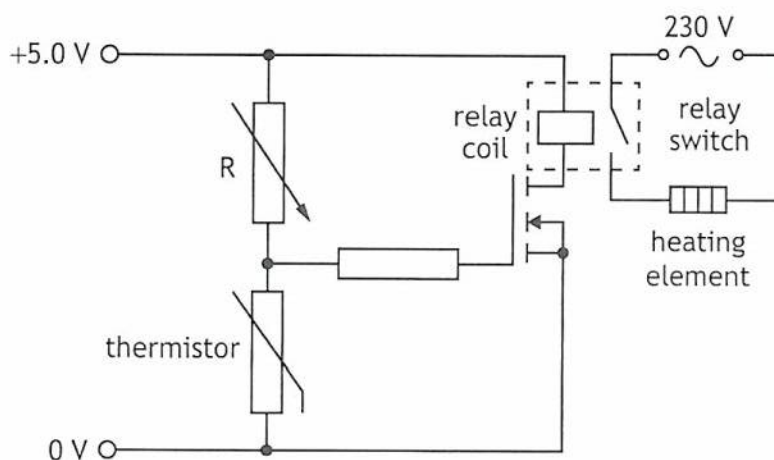

As the temperature of the water increases, the resistance of the thermistor decreases.

The heating element is switched off when the temperature of the water reaches 65 °C.

Explain how the circuit operates to switch off the heating element.

3

[Turn over



7. A volume of gas is trapped in a capillary tube by a bead of liquid, as shown.

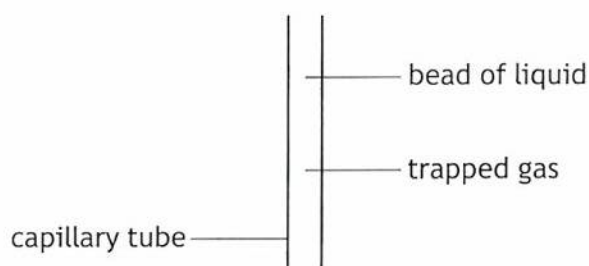

A student carries out an experiment to investigate the relationship between the volume of gas in the tube and its temperature at a constant pressure.

The student places the capillary tube in a beaker of hot water and takes measurements of the length of the gas trapped in the tube and temperature as the gas cools.

The student uses the measurements of the length to determine the volume of the gas trapped in the tube.

The student produces the following graph of their results.

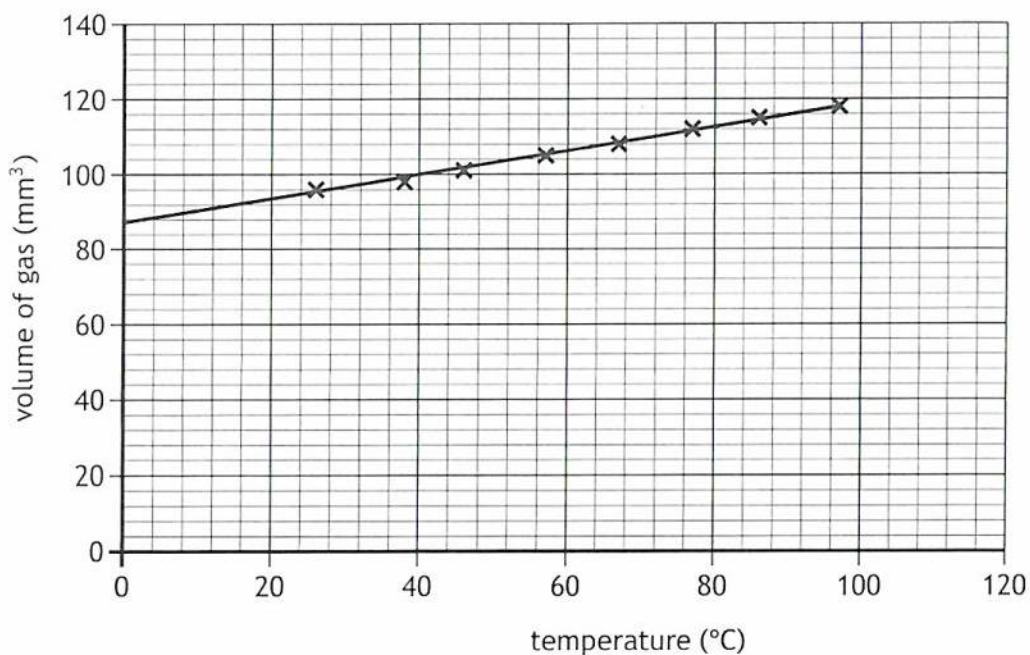

* X 8 5 7 7 5 0 1 2 4 *

7. (continued)

MARKS
DO NOT
WRITE IN
THIS
MARGIN

- (a) The student wants to show that the volume of the gas is directly proportional to its temperature.

Explain why the student's graph does not demonstrate this relationship.

2

- (b) State the effect that decreasing the temperature of the gas has on the gas particles in the capillary tube.

1

- (c) When carrying out the experiment, the student stirs the water in the beaker at regular intervals.

Explain why stirring the water is good experimental practice.

1

- (d) The cross-sectional area of the capillary tube is $0.82 \times 10^{-6} \text{ m}^2$.

The pressure of the gas in the capillary tube is $1.02 \times 10^5 \text{ Pa}$.

Calculate the upward force exerted on the bead of liquid by the gas.

3

Space for working and answer



* X 8 5 7 7 5 0 1 2 5 *

8. A colour mixing ray box uses three colours of LED: red, green, and blue. A student sets the ray box to emit green light. The student directs a ray of green light through a glass block as shown.

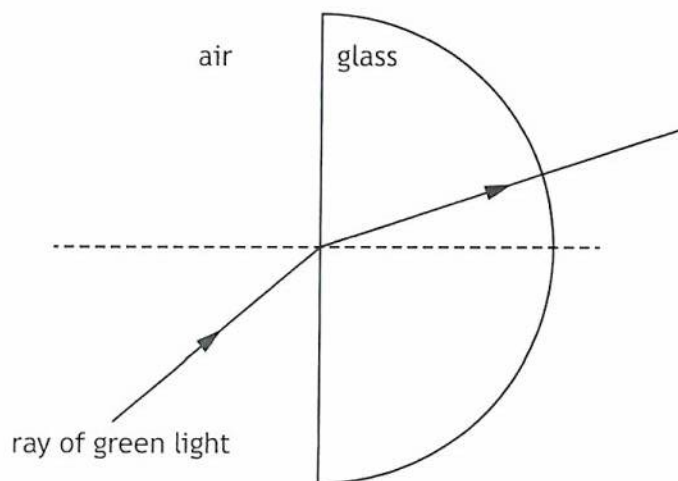

- (a) On the diagram above, label the angle of incidence i , the angle of refraction r , and the normal.

1

(An additional diagram, if required can be found on page 41.)

- (b) (i) The student varies the angle of incidence and measures the corresponding angles of refraction.

The results are shown in the table.

Angle of incidence ($^{\circ}$)	Angle of refraction ($^{\circ}$)
30	19
40	25
60	35
70	39
80	41



8. (b) (i) (continued)

Using the graph paper, draw a graph of the student's results.
 (Additional graph paper, if required, can be found on *page 41*.)

3

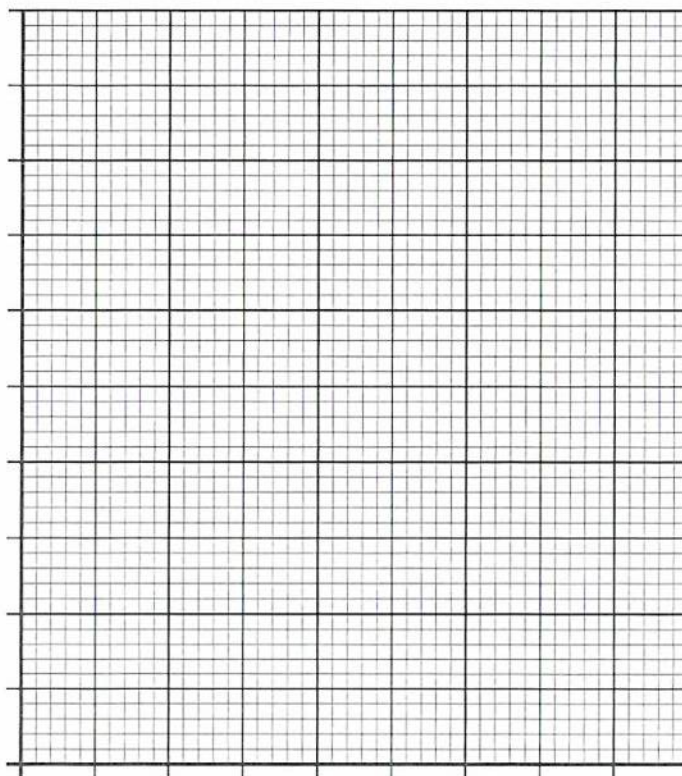

(ii) Using your graph, determine the angle of refraction when the angle of incidence is 50° .

1

[Turn over



8. (continued)

(c) A simplified circuit diagram for the three LEDs is shown.

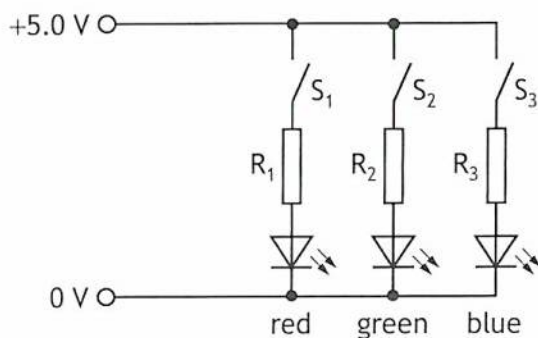

When S_2 is closed the voltage across the green LED is 2.2 V and the current in the LED is 25 mA.

Determine the resistance of resistor R_2 in series with the LED.

4

Space for working and answer



8. (continued)

(d) The table below shows the peak wavelength of the light from the red, green, and blue LEDs.

Colour	Peak wavelength (nm)
Red	620
Green	520
Blue	460

(i) Calculate the frequency of the light from the green LED.

3

Space for working and answer

(ii) The greater the frequency of the light, the more the light refracts as it enters the glass block.

A second student repeats the experiment using the same angles of incidence as the first student.

State the colour of LED, from the ray box, that will produce angles of refraction **less than** those obtained by the first student.

Justify your answer.

2

[Turn over



9. A group of Physics students are part of a large crowd at a music festival.



During the concert, the students enjoy the music and light show. They also experience the motion of the crowd.

Using your knowledge of physics, comment on how the observations of the students can be used to discuss the properties of different types of waves.

3



10. Bats use high frequency sound waves to detect objects and hunt for prey.

At a particular instant a bat is hovering at a constant height a short distance from a wall.

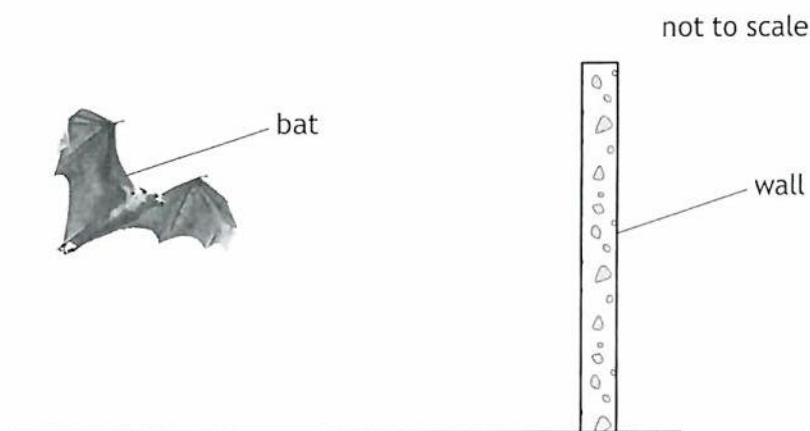

- (a) At this instant the bat emits sound waves, which reflect from the wall and are then detected by the bat.

The time between the sound being emitted and detected by the bat is 0.028 s.

Determine the distance between the bat and the wall.

4

Space for working and answer

- (b) Describe how the upward lift force exerted by the bat's wings compares to the weight of the bat when it is hovering at a constant height.

1



* X 8 5 7 7 5 0 1 3 2 *

10. (continued)

- (c) The bat now flies towards the wall at a speed of 8.6 m s^{-1} .

As the bat moves towards the wall the frequency of the sound incident on the wall will be higher than the frequency of the sound emitted by the bat.

The frequency of the sound wave incident on the wall can be calculated using the relationship

$$f_w = \left(\frac{v}{v - v_{bat}} \right) \times f_{bat}$$

where: f_w is the frequency of the sound incident on the wall in Hz

v is the speed of sound in air in m s^{-1}

v_{bat} is the speed of the bat in m s^{-1}

f_{bat} is the frequency of sound emitted by the bat in Hz.

The frequency of sound emitted by the bat is 64 kHz.

- (i) State what is meant by a frequency of 64 kHz. 1

- (ii) Calculate the frequency of sound incident on the wall. 2
Space for working and answer

[Turn over



11. A technician carries out an experiment, using the apparatus shown, to investigate the penetration of ionising radiation from a radioactive source.

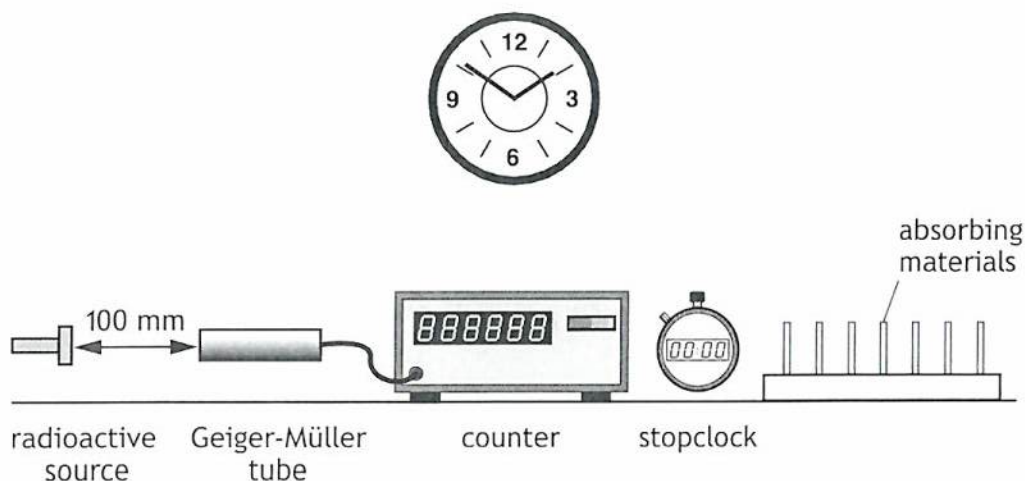

The technician measures the count rate from the radioactive source with no absorber between the source and Geiger-Müller tube.

The technician then places an aluminium sheet with a thickness of 6 mm between the radioactive source and Geiger-Müller tube. This causes the count rate to decrease.

- (a) The technician concludes that the radioactive source is emitting alpha radiation.

Give **two** reasons why this experiment does not allow the technician to make this conclusion.

2

- (b) The technician then carries out a second experiment to determine the half-life of a different radioactive source by measuring the count rate at regular time intervals.

- (i) Before carrying out the experiment, the technician measures the background count rate.

Explain why the technician measures the background count rate.

1



11 . (b) (continued)

MARKS
DO NOT
WRITE IN
THIS
MARGIN

(ii) The technician's results are shown in the graph.

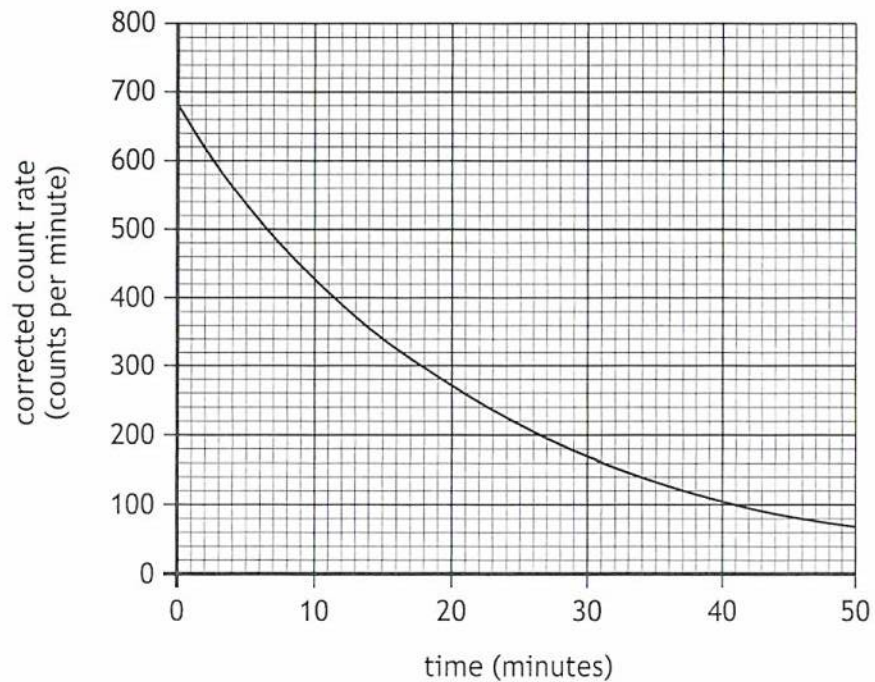

(A) Using the graph, determine the half-life of the radioactive source.

1

(B) Determine the time taken for the corrected count rate to reach one sixteenth of its original value.

2

Space for working and answer

(iii) State a safety precaution that the technician must follow when handling a radioactive source.

1



* X 8 5 7 7 5 0 1 3 5 *

12. Gold-198 is used as a radioactive source in the treatment of cancer.
 A sample of gold-198 with an initial activity of 74 MBq is prepared to treat a patient.

The half-life of gold-198 is 2.7 days.

(a) The sample must be used within 48 hours.

Explain why the sample will be less effective after this time.

1

(b) Gold-198 emits beta particles.

The sample is placed next to the cancerous tissue.

While the sample is in position, 5.0×10^{11} beta particles irradiate the cancerous tissue.

The energy of each beta particle is 0.960 MeV.

(1 MeV = 1.60×10^{-13} J)

The mass of tissue exposed to the beta particles is 0.064 kg.

(i) State what is meant by a *beta particle*.

1

(ii) (A) Determine the energy, in joules, of a beta particle.

1

Space for working and answer



12. (b) (ii) (continued)

MARKS DO NOT WRITE IN THIS MARGIN

(B) Determine the absorbed dose received by the tissue.

3

Space for working and answer

(iii) Calculate the equivalent dose received by the tissue.

3

Space for working and answer

[END OF QUESTION PAPER]

