



National
Qualifications
2024

X857/75/02

Physics
Section 1 — Questions

THURSDAY, 25 APRIL

1:00 PM – 3:30 PM

Instructions for the completion of Section 1 are given on *page 02* of your question and answer booklet X857/75/01.

Record your answers on the answer grid on *page 03* of your question and answer booklet.

Reference may be made to the data sheet on *page 02* of this booklet and to the relationships sheet X857/75/11.

Before leaving the examination room you must give your question and answer booklet to the Invigilator; if you do not, you may lose all the marks for this paper.



* X 8 5 7 7 5 0 2 *

Downloaded free from <https://sqa.my/>

DATA SHEET

Speed of light in materials

Material	Speed in m s^{-1}
Air	3.0×10^8
Carbon dioxide	3.0×10^8
Diamond	1.2×10^8
Glass	2.0×10^8
Glycerol	2.1×10^8
Water	2.3×10^8

Speed of sound in materials

Material	Speed in m s^{-1}
Aluminium	5200
Air	340
Bone	4100
Carbon dioxide	270
Glycerol	1900
Muscle	1600
Steel	5200
Tissue	1500
Water	1500

Gravitational field strengths

	Gravitational field strength on the surface in N kg^{-1}
Earth	9.8
Jupiter	23
Mars	3.7
Mercury	3.7
Moon	1.6
Neptune	11
Saturn	9.0
Sun	270
Uranus	8.7
Venus	8.9

Specific heat capacity of materials

Material	Specific heat capacity in $\text{J kg}^{-1} \text{ }^\circ\text{C}^{-1}$
Alcohol	2350
Aluminium	902
Copper	386
Glass	500
Ice	2100
Iron	480
Lead	128
Oil	2130
Water	4180

Specific latent heat of fusion of materials

Material	Specific latent heat of fusion in J kg^{-1}
Alcohol	0.99×10^5
Aluminium	3.95×10^5
Carbon dioxide	1.80×10^5
Copper	2.05×10^5
Iron	2.67×10^5
Lead	0.25×10^5
Water	3.34×10^5

Melting and boiling points of materials

Material	Melting point in $^\circ\text{C}$	Boiling point in $^\circ\text{C}$
Alcohol	-98	65
Aluminium	660	2470
Copper	1077	2567
Lead	328	1737
Iron	1537	2737
Water	-	100

Specific latent heat of vaporisation of materials

Material	Specific latent heat of vaporisation in J kg^{-1}
Alcohol	11.2×10^5
Carbon dioxide	3.77×10^5
Glycerol	8.30×10^5
Turpentine	2.90×10^5
Water	22.6×10^5

Radiation weighting factors

Type of radiation	Radiation weighting factor
alpha	20
beta	1
fast neutrons	10
gamma	1
slow neutrons	3
X-rays	1

SECTION 1 — 25 marks

Attempt ALL questions

1. Which row in the table classifies speed, weight, and energy correctly?

	Speed	Weight	Energy
A	scalar	scalar	scalar
B	vector	scalar	vector
C	scalar	vector	vector
D	vector	vector	vector
E	scalar	vector	scalar

2. A student uses the apparatus shown to determine the average speed and instantaneous speed of a trolley as it travels down a slope.

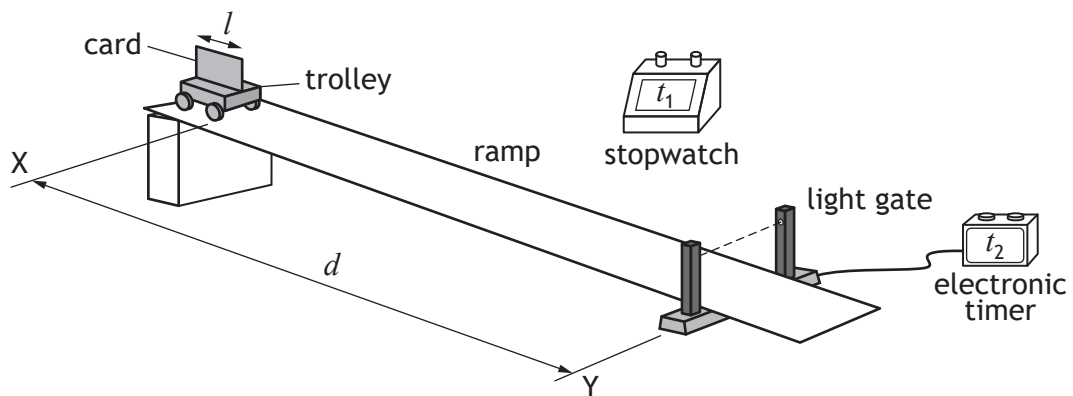

The trolley is released at X and travels down the slope.

The distance between X and the light gate at Y is d .

The time taken for the trolley to reach the light gate is t_1 .

The length of the card on the trolley is l .

The time taken for the card to pass through the light gate is t_2 .

Which row in the table shows the measurements required to determine the average speed of the trolley between X and Y, and the instantaneous speed of the trolley at Y?

	Measurements for average speed between X and Y	Measurements for instantaneous speed at Y
A	l and t_1	d and t_2
B	d and t_1	l and t_2
C	l and t_2	d and t_1
D	d and t_2	l and t_2
E	d and t_1	l and t_1

3. A rocket is taking off from the surface of the Earth. The rocket engines exert a force on the exhaust gases.

Which of the following is the reaction to this force?

- A The force of the Earth on the exhaust gases.
 - B The force of the Earth on the rocket engines.
 - C The force of the rocket engines on the Earth.
 - D The force of the exhaust gases on the Earth.
 - E The force of the exhaust gases on the rocket engines.
4. A motor raises a mass of 2400 kg vertically through a height of 5.0 m in 2 minutes.
The minimum power rating of the motor to raise the mass is
- A 100 W
 - B 980 W
 - C 24 000 W
 - D 59 000 W
 - E 120 000 W.
5. A satellite is in circular orbit around a planet.

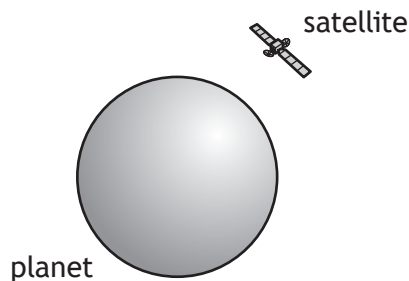

A group of students make the following statements about the satellite in orbit:

- I The horizontal speed of the satellite is constant.
- II The satellite does not move.
- III While orbiting the planet the satellite is weightless.

Which of these statements is/are correct?

- A I only
- B II only
- C III only
- D I and III only
- E II and III only

6. A pulse of light from a laser is transmitted from the Earth to the Moon.

The light reflects from a mirror on the Moon and is detected back on Earth 2.6 s after being transmitted.

The distance from the Earth to the Moon is

- A 8.8×10^2 m
 - B 1.2×10^8 m
 - C 2.3×10^8 m
 - D 3.9×10^8 m
 - E 7.8×10^8 m.
7. The table shows the altitude and period of four satellites.

Satellite	Altitude (km)	Period (minutes)
International Space Station	408	93
AprizeSat-3	686	
Intelsat-18	35 800	1440
Hubble Space Telescope	537	95

The period of the AprizeSat-3 satellite is

- A 85 minutes
 - B 94 minutes
 - C 98 minutes
 - D 1440 minutes
 - E 1600 minutes.
8. A student makes the following statements about the Universe:
- I One light-year is the time taken for light to travel from the Sun to the Earth.
 - II The approximate age of the Universe is 13.8 billion years.
 - III The 'Big Bang' theory describes the origin of the Universe.

Which of these statements is/are correct?

- A II only
- B III only
- C I and III only
- D II and III only
- E I, II and III

9. An electric field exists around two point charges Q and R. The diagram shows the path taken by a charged particle as it travels through the field. The motion of the particle is as shown.

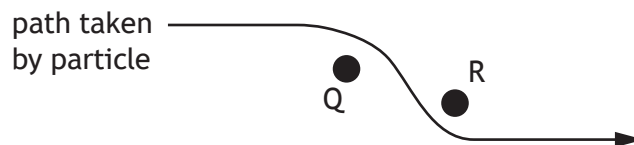

Which row in the table identifies the charge on the particle, the charge on Q, and the charge on R?

	Charge on particle	Charge on Q	Charge on R
A	positive	negative	negative
B	negative	negative	positive
C	negative	positive	negative
D	positive	negative	positive
E	positive	positive	positive

10. A toaster is connected to a 230 V mains supply and switched on. The heating element in the toaster has a power rating of 1.2 kW. A student makes the following statements about the toaster:
- I The heating element transfers 12 000 J of electrical energy each second.
 - II The plug of the toaster should be fitted with a fuse rated at 13 A.
 - III The charge passing through the heating element each second is 230 C.

Which of these statements is/are correct?

- A I only
- B II only
- C I and II only
- D II and III only
- E I, II and III

11. A circuit is set up as shown.

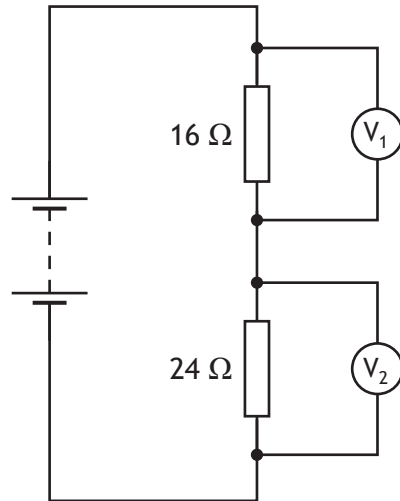

The reading on voltmeter V_1 is 3.6 V.

The reading on voltmeter V_2 is

- A 0.4 V
- B 2.2 V
- C 2.4 V
- D 3.6 V
- E 5.4 V.

[Turn over

12. A circuit is set up as shown.

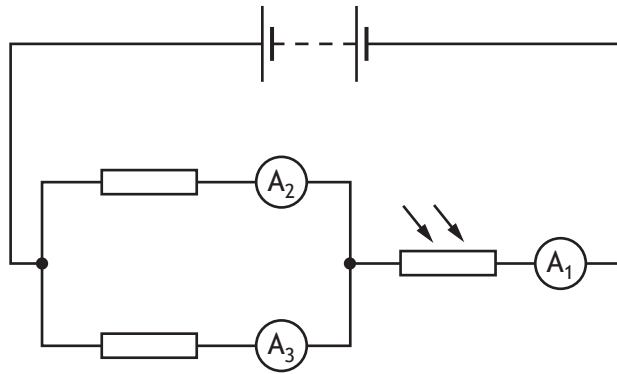

The resistance of the LDR increases as the light level decreases.

The light level incident on the LDR decreases.

Which row in the table describes the effect of this change on the readings on the ammeters?

	Reading on ammeter A ₁	Reading on ammeter A ₂	Reading on ammeter A ₃
A	decreases	decreases	decreases
B	decreases	stays the same	stays the same
C	stays the same	stays the same	stays the same
D	increases	stays the same	stays the same
E	increases	increases	increases

13. Three resistors are connected as shown.

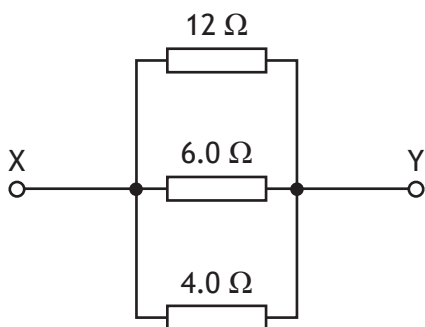

The total resistance between X and Y is

- A 0.5 Ω
- B 2.0 Ω
- C 4.0 Ω
- D 6.0 Ω
- E 22 Ω.

14. A length of wire has a resistance of 8.0Ω .
The current in the wire is 1.5 A .
The power developed in the wire is

- A 5.3 W
- B 12 W
- C 18 W
- D 43 W
- E 96 W .

15. A student carries out an experiment to determine the specific heat capacity of copper.
The setup used by the student is shown.

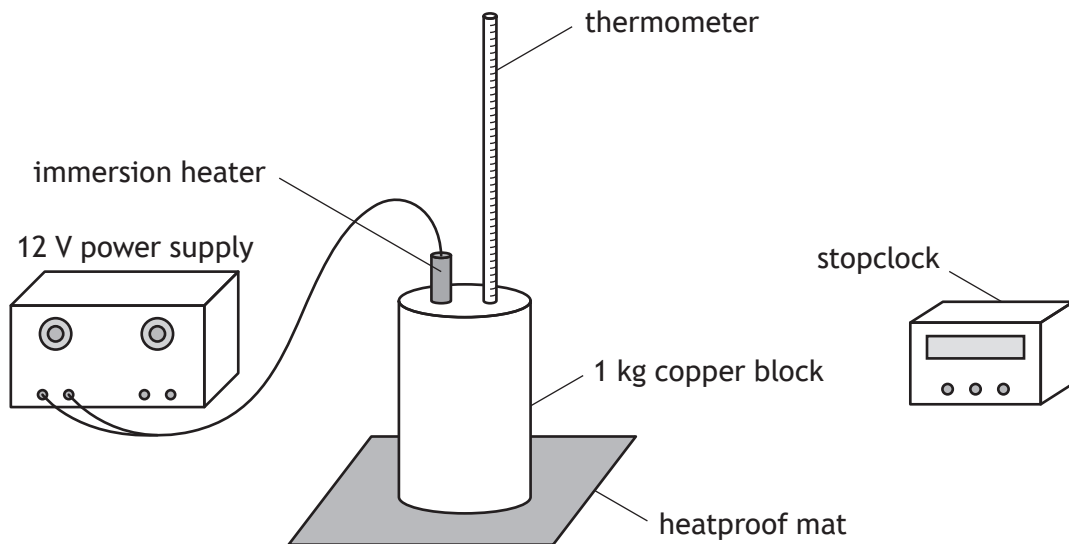

The student heats the copper block for 5 minutes.

The temperature of the block increases by $14 \text{ }^\circ\text{C}$.

The value of the specific heat capacity of copper determined by the student using this method is found to be inaccurate.

Which of the following changes would improve the accuracy of this experiment?

- A Heating the copper block for a longer time.
- B Placing insulation around the copper block.
- C Replacing the copper block with one of less mass.
- D Replacing the immersion heater with one of a higher power rating.
- E Removing the heatproof mat.

[Turn over

16. A solid substance is placed in an insulated container and heated.
The graph shows how the temperature T of the substance varies with time t .

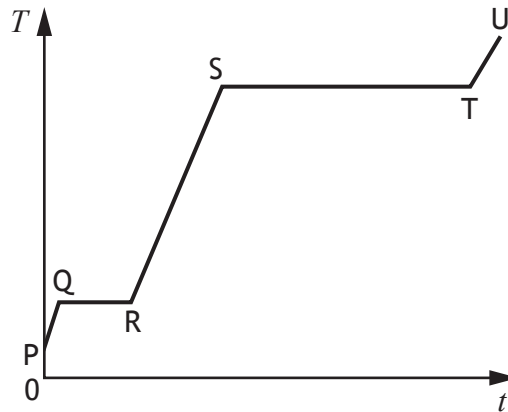

To determine the specific latent heat of vaporisation of the substance, a student would use the time from section

- A PQ
 - B QR
 - C RS
 - D ST
 - E TU.
17. A syringe containing air is sealed at one end as shown.

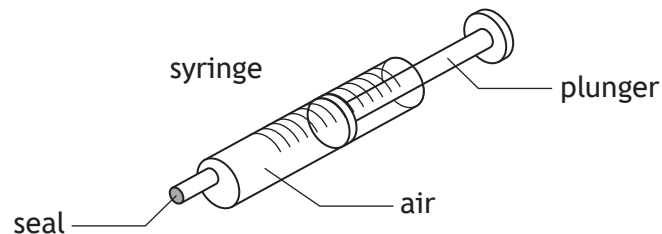

The initial volume of the air in the syringe is $1.40 \times 10^{-6} \text{ m}^3$ and the pressure is 120 kPa.
The plunger is pushed in causing the volume to be **reduced by** $0.30 \times 10^{-6} \text{ m}^3$.
The temperature of the air inside the syringe remains constant.
The pressure of the air inside the syringe is now

- A 26 kPa
- B 94 kPa
- C 99 kPa
- D 153 kPa
- E 560 kPa.

18. The size of the buoyancy force F_b acting on an object immersed in a fluid is given by the relationship

$$F_b = \rho g V$$

where: ρ is the density of the fluid in kg m^{-3}

g is the gravitational field strength in N kg^{-1}

V is the volume of the object in m^3 .

The volume of an object that experiences a buoyancy force of 360 N when immersed in a fluid of density 1020 kg m^{-3} is

- A 0.036 m^3
 - B 0.33 m^3
 - C 3.5 m^3
 - D 28 m^3
 - E 37 000 m^3 .
19. The diagram represents a wave travelling from X to Y.

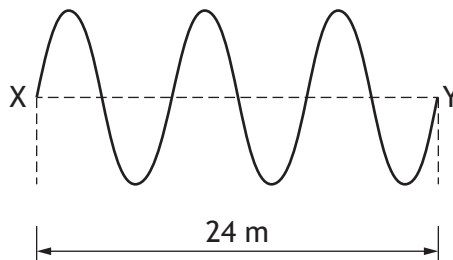

The speed of the wave is 48 m s^{-1} .

The frequency of the wave is

- A 0.50 Hz
- B 2.0 Hz
- C 6.0 Hz
- D 144 Hz
- E 384 Hz.

[Turn over

20. The letters X, Y, and Z represent missing words or phrases from the following passage.

Infrared has aX.... wavelength than visible light.

Infrared diffractsY.... than visible light.

The speed of infrared isZ.... visible light.

Which row in the table shows the missing words or phrases?

	X	Y	Z
A	longer	less	the same as
B	shorter	less	slower than
C	longer	more	the same as
D	shorter	more	faster than
E	longer	more	faster than

21. The diagram shows the path of a ray of red light as it passes through and out of a semicircular glass block.

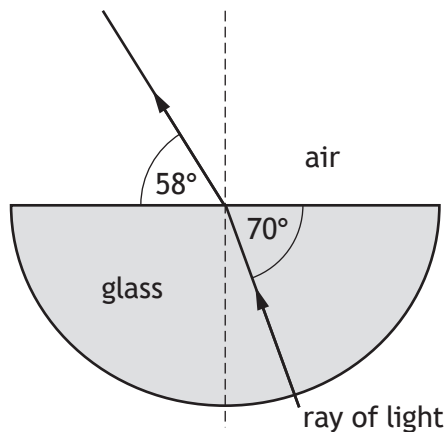

Which row in the table shows the angle of incidence in the glass and the angle of refraction in air?

	Angle of incidence in glass	Angle of refraction in air
A	20°	32°
B	32°	20°
C	58°	70°
D	70°	32°
E	70°	58°

22. Which of the following statements describes the term *ionisation*?

- A The removal of a proton from an atom to form a charged particle.
- B The removal of an electron from an atom to form a charged particle.
- C The removal of a neutron from an atom.
- D The splitting of a large nucleus into smaller nuclei.
- E The joining of small nuclei to form a larger nucleus.

23. In a radioactive source 1.8×10^6 nuclei decay in 10 hours.

The activity of the source is

- A 1.8×10^5 Bq
- B 3.0×10^4 Bq
- C 3.0×10^3 Bq
- D 500 Bq
- E 50 Bq.

24. A sample of tissue receives an absorbed dose of $0.20 \mu\text{Gy}$ from a source of alpha radiation and an absorbed dose of $6.0 \mu\text{Gy}$ from a source of slow neutrons.

The total equivalent dose received by the sample of tissue is

- A $6.2 \mu\text{Sv}$
- B $19 \mu\text{Sv}$
- C $22 \mu\text{Sv}$
- D $64 \mu\text{Sv}$
- E $140 \mu\text{Sv}$.

[Turn over

25. A technician carries out an experiment, using the apparatus shown, to determine the half-life of a radioactive source.

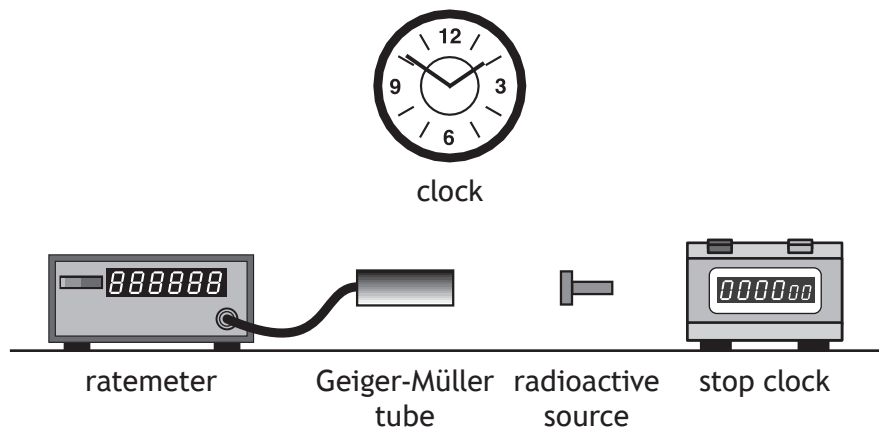

Before carrying out the experiment the technician measures the background count rate.

The technician takes readings of the count rate displayed on the ratemeter every 60 s for a period of 20 minutes.

A graph of the technician's measurements is as shown.

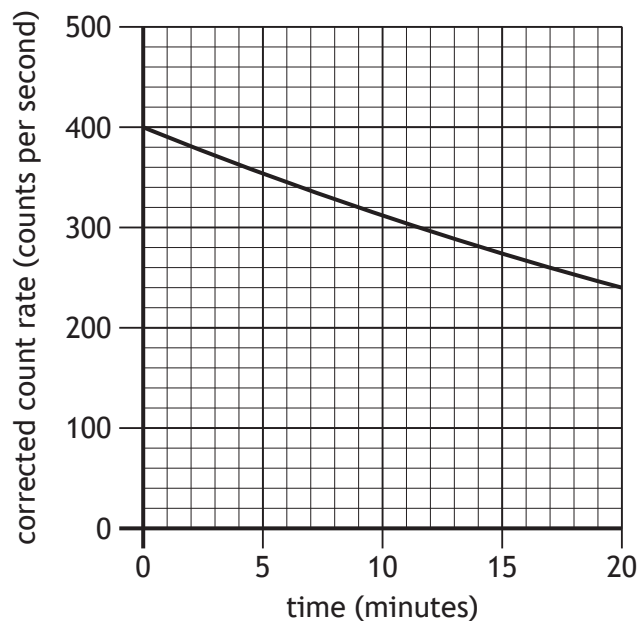

Which of the following changes would allow the technician to more easily determine the half-life of the radioactive source?

- A Take readings of the count rate every 30 seconds for 20 minutes.
- B Take readings of the count rate every 60 seconds for 40 minutes.
- C Place lead shielding around the radioactive source.
- D Move the radioactive source closer to the Geiger-Müller tube.
- E Move the radioactive source further away from the Geiger-Müller tube.

[END OF SECTION 1. NOW ATTEMPT THE QUESTIONS IN SECTION 2 OF YOUR QUESTION AND ANSWER BOOKLET]

[BLANK PAGE]

DO NOT WRITE ON THIS PAGE

[BLANK PAGE]

DO NOT WRITE ON THIS PAGE